

## Model 2025

### Pneudraulic Installation Tool

#### Specifications

*Weight:*

5.75 lbs.

*Required Air Pressure:*

90-110 psi

*Air Consumption:*

1.4 CFM based on 30 cycles per minute

*Hydraulic Fluid:*

Automatic Transmission Fluid  
DEXTRON II® or equivalent

*Stroke:*

0.675 in.

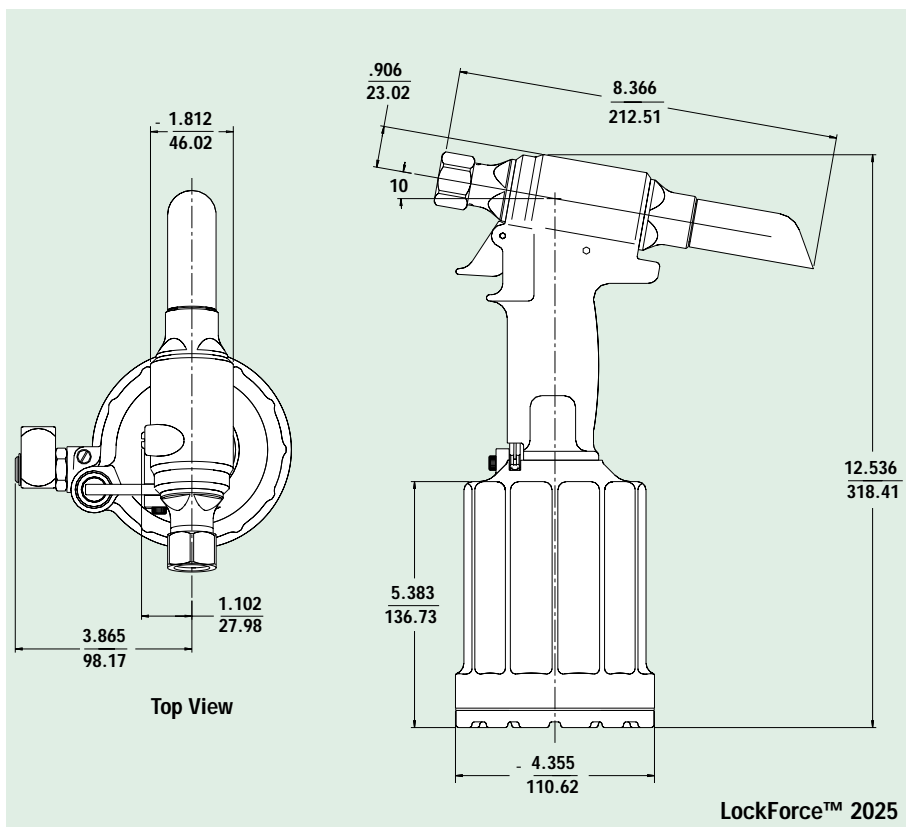

#### Compatible Fastener

Type	Diameter	Nose Assembly
BOM	3/16	99-994
MAGNA-LOK	3/16	99-3303
	1/4	99-3305
MAGNA-BULB	3/16	99-3303
	1/4	99-3305
AUTO-BULB	3/16	99-3303
	1/4	99-3305
MAGNA-GRIP	3/16	99-3201
	1/4	99-3204
HUCKTAINER	-12	99-3465
C6L	3/16	99-3003
	1/4	99-3006

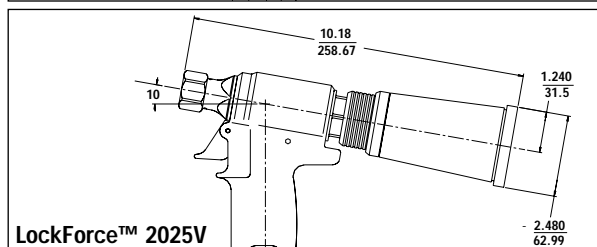
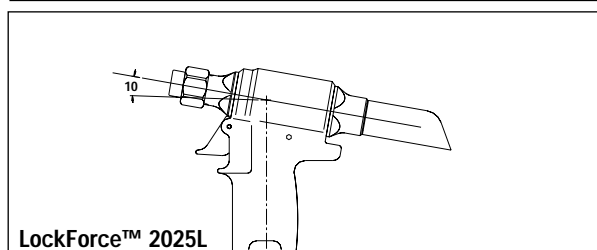

Designed for production volume fastening, the LockForce™ 2025 offers a number of outstanding features, including an ergonomically designed handle, plated piston rods and efficient in-line piston. An extended piston version (2025L) is available and an optional vacuum assist pintail collection system (2025V) can be added.