

POP[®]

ProSet[®] 2500 Rivet Tool

Get the power, lose the weight.

The ProSet[®] 2500 tool sets new standards for pneumatic rivet tools. Designed specifically to set a wide range of blind rivets, including 3/16" (4.8mm) High Strength and Stainless Steel, this tool delivers 2,110 lbs. (9.4 kN) of pulling force with a "highest in class" force-to-weight ratio of 730 lbf/lb (7.18 kN/kg).

The ProSet[®] 2500 tool features many innovative high performance features including a patented "Quick Disconnect" nose housing and jaw case for rapid cleaning and maintenance of the front end without the need for any tools. With the 2500 "Quick Disconnect" Mandrel Collection System (MCS), mandrels are safely collected for easy disposal and cleaner work areas. An air-isolation switch on the MCS prevents air flow when the MCS is disconnected. The tough aluminum casing is designed to prevent damage and enhance the life of the tool.

A left or right 90° swivel air fitting ensures the tool can be adapted to virtually any workstation configuration, while the "on/off" switch minimizes air consumption. The spring return ensures fast, reliable setting cycles reducing operating cost. An extended 5" (140mm) front end is also available for extra reach in special setting situations. The ProSet[®] 2500 is compatible with other Emhart Teknologies automation systems including the remote Mandrel Collection System (MCS5000), the POP[®] Rivet Presenter (RP) and the SmartSet[®]. The 2500 series will set 2mm Micro Rivets, 3/32" (2.4mm), 1/8" (3.2mm), 5/32" (4.0mm) and 3/16" (4.8mm) diameter rivets in all materials including high strength structural stainless steel rivets.



Features & Benefits:

- **Ergonomic**
 - Lightweight polymer construction*
 - Comfortable two finger, low activation force trigger*
 - Directionable air exhaust (MCS model)*
- **Performance**
 - High force-to-weight ratio*
 - Quick disconnect nose housing*
 - Quick disconnect jaw case*
 - Quick disconnect Mandrel Collection System*
- **Economy**
 - On/Off, left or right swivel air fitting*
 - Spring return for a reliable fast setting cycle*
- **Adaptability**
 - Extended 5" (140mm) long front end for extra reach*
 - POP[®] Rivet Presenter (RP) compatible*
 - POP[®] SmartSet[®] rivet monitoring system compatible*
- **Safety**
 - Air-isolation switch during MCS removal*



Quick Disconnect
Mandrel Collector



Quick Disconnect
Nosehousing



Quick Disconnect Jaw
Guide Technology



www.emhart.com

**Emhart[®]
Teknologies**
POP[®]

POP® ProSet® 2500 Rivet Tool

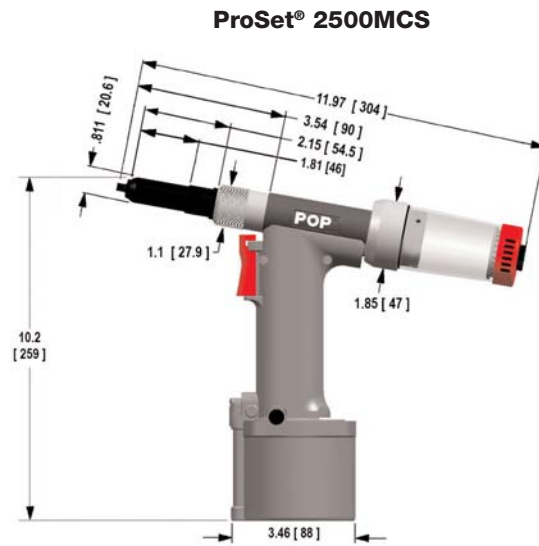
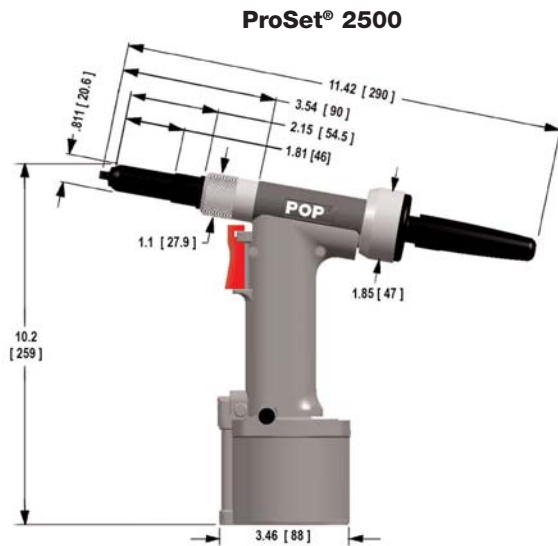

Note: Dimensions above inches [mm]

Specifications

Model Number	ProSet® 2500	ProSet® 2500MCS
Weight	2.65 lbs. (1.20 kg)	2.89 lbs. (1.31 kg)
Length	11.42" (290 mm)	11.97" (304 mm)
Height	10.20" (259 mm)	10.20" (259 mm)
Tool stroke	0.71" (18 mm)	0.71" (18 mm)
Pulling force	2110 lbs @ 90 psi (9400 N @ 6.2 bar)	2110 lbs @ 90 psi (9400 N @ 6.2 bar)
Force/Weight ratio	796.2 lbf/lb (7.83 kN/kg)	730 lbf/lb (7.18 kN/kg)
Air consumption	0.076 cu. ft./rivet (2.15 liters/rivet)	2.47 scfm (max) [70 liters/min (max)]

Rivet Capacity

Rivet Type	Material (Body-Mandrel)	Rivet Diameter		
		1/8"(*) (3.0-3.2 mm)	5/32"(*) (4.0 mm)	3/16"(**) (4.8 mm)
Open End & Multi-Grip™	Aluminum-Aluminum	✓	✓	✓
	Aluminum-Steel / St. Steel	✓	✓	✓
	Steel-Steel	✓	✓	✓
	St. Steel-St. Steel	✓	✓	✓(†)
	Monel-Steel / St. Steel	✓	✓	✓(†)
Closed End	Aluminum-Aluminum	✓	✓	✓
	Aluminum-Steel / St. Steel	✓	✓	✓
	Copper-Steel	✓	✓	✓
	Steel-Steel	✓	✓	✓
	St. Steel-St. Steel	✓	✓	✓
LSR Rivets	Aluminum-Aluminum	✓	✓	✓
HR™ Rivets	Steel-Steel	✓	✓(**)	✓
T Rivet	Aluminum-Steel	✓	✓	✓
Self Plugger	Steel-Steel	✓	✓	✓
UltraGrip™	Aluminum-Aluminum	-	-	✓
	Steel-Steel	-	-	✓
	St. Steel-St. Steel	-	-	✓

Optional Accessories

Part Number	Description
DPN239-110	17mm Hex. Socket Screw Key
FAN275-132	Front End 5" (140mm) Extension kit
FAN275-133	ProSet® 2500 Seal kit
FA203-408	Adaptor kit for Remote MCS (MCS5000)
FAN275-134	Mandrel Collection System Retrofit kit
FAN275-198	Reduce Diameter Front End Kit



MCS Retrofit Kit



Extended Nose Housing Available

(*) Use FAN275-028 Jaw pusher set up; (**) Use DPN275-027 Jaw pusher set up.

(†) Excludes Multi-Grip™ Note: St. Steel: Stainless Steel

Americas

Emhart Teknologies
50 Shelton Technology Center
P.O. Box 859
Shelton, CT 06484 USA
Tel: (877) EMHART1
Fax: (800) 225-5614

Canada: (514) 351-0330
Brazil: + 55 11 3871-6460
México: + 52-55-5326-7100

Europe

Emhart Teknologies
177 Walsall Road, Perry Barr
Birmingham, B42 1BP, UK
Tel: +44 (0) 121 331-2460
Fax: +44 (0) 121 356-1598

Asia Pacific

Emhart Teknologies
Shuwa Kioicho Park, Bldg 3F
3-6 Kioicho, Chiyoda-Ku
Tokyo 102-0094, Japan
Tel: +81 (03) 3265-7291
Fax: +81 (03) 3265-7298

**Emhart
Teknologies**
POP®

A BLACK & DECKER COMPANY