

POP[®]

ProSet™ 1600 Rivet Tool

Great power in a reliable, lightweight and compact rivet tool.

The ProSet™ 1600 is among the highest force-to-weight ratio blind riveting tools in the industry. In addition to its compact design, the comfortable, small rounded grip reduces user fatigue and increases ability to maneuver in tight spaces.

The ProSet™ 1600 will keep your production lines running at full speed. Thanks to the innovative quick disconnect nose housing, the front end components can be serviced in minutes - without tools. With the 1600 Mandrel Collection System (MCS) model, spent mandrels are instantly collected, and with the quick disconnect system, disposal takes no time, keeping work areas safe and clean with minimal downtime.

This ProSet™ 1600 model also features an innovative left or right, On/Off swivel air fitting providing additional flexibility, conserving energy and reducing operating costs. The 1600 will set 2.0 mm Micro Rivets, 3/32" (2.4mm) and 1/8" (3.2mm) diameter rivets in all materials and up to 5/32" (4.0mm) all steel open end rivets.

Features & Benefits:

- **Ergonomic**
Lightweight polymer construction
Comfortable two finger, low activation force trigger
Directionable air exhaust
- **Performance**
High force-to-weight ratio
Quick disconnect nose housing
Quick disconnect jaw case
Quick disconnect Mandrel Collector
- **Economy**
Conserve energy, On/Off, left or right swivel air fitting
- **Adaptability**
Capable of setting 2.0 mm Micro Rivets
Extended 5" long front end for extra reach
POP® Rivet Presenter (RP) compatible



Lightweight and comfortable to operate



Quick disconnect Nosehousing



Quick disconnect Jaw Guide technology



www.emhart.com

Emhart[®]
Teknologies
POP[®]

POP® ProSet™ 1600 Riveting System

ProSet™ 1600

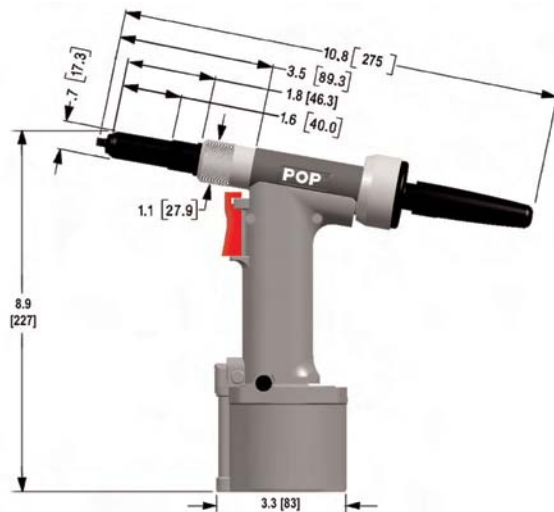

ProSet™ 1600 MCS

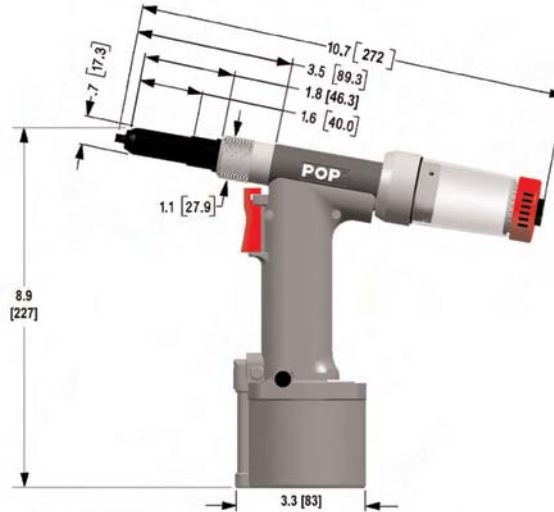

Specifications

Model Number	ProSet™ 1600	ProSet™ 1600MCS
Weight	2.14 lbs. (0.97 kg)	2.29 lbs. (1.04 kg)
Length	10.83" (275 mm)	10.71" (272 mm)
Height	8.94" (227 mm)	
Tool stroke	0.71" (18 mm)	
Working pressure	72.5 - 100 psi (5.0 - 6.9 bar)	
Pulling force	1090 lbs @ 90 psi (4850 N @ 6.2 bar)	
Force/Weight ratio	509 lbf/lb (5 kN/kg)	476 lbf/lb (4.6 kN/kg)
Air consumption	0.043 cu. ft./rivet (1.22 liters/rivet)	2.47 scfm (max) [70 liters/min (max)]

Rivet Capacity

Rivet Type	Material (Body-Mandrel)	Rivet Diameter		
		3/32" (*) (2.4 mm)	1/8" (3.0-3.2 mm)	5/32" (4.0 mm)
Open End & Multi-Grip	Aluminum-Aluminum	✓	✓	✓
	Aluminum-Steel or St. Steel (**)	✓	✓	✓
	Steel-Steel	✓	✓	✓ ^(†)
	St. Steel-St. Steel; Monel-Steel or St. Steel	✓	✓	
Closed End	Aluminum-Aluminum	✓	✓	✓
	Aluminum-Steel or St. Steel	✓	✓	✓ ^(‡)
	Copper-Steel	✓	✓	
	Steel-Steel	✓	✓	
LSR Rivets	Aluminum-Aluminum	✓	✓	✓
HR™ Rivets	Steel-Steel	✓	✓	
"T" Rivet	Aluminum-Steel	✓	✓	✓
Self Plugger	Steel-Steel	✓	✓	
MCS Collector Capacity (# Mandrels)		300	120	90

Optional Accessories

Part Number	Description
PRN214	Nosepiece for 2.0 mm Micro Rivets
PRG402-02	Jaws for 2.0 mm Micro Rivets
FAN239-174	Front End 5" Length Extension Kit
FA203-408	Adaptor Kit for MCS5000 (remote MCS)
FAN239-177	MCS Retrofit Kit - Convert 1600 Model



Insist on Genuine POP® Rivets



Extended nose housing

(*) Use FAN239-176 Jaw pusher set up; (†) Excludes MultiGrip; (‡) Set air pressure at 90 psi (6.2 bar).

(**) St. Steel - Stainless Steel

Americas

Emhart Teknologies
50 Shelton Technology Center
P.O. Box 859
Shelton, CT 06484 USA
Tel: (203) 924-9341
Fax: (800) 225-5614

Canada: (514) 351-0330
Brazil: + 55 11 3871-6460
México: + 52-55-5326-7100

Europe

Emhart Teknologies
177 Walsall Road, Perry Barr
Birmingham, B42 1BP, UK
Tel: +44 (0) 121 331-2460
Fax: +44 (0) 121 356-1598

Asia Pacific

Emhart Teknologies
Shuwa Kioicho Park, Bldg 3F
3-6 Kioicho, Chiyoda-Ku
Tokyo 102-0094, Japan
Tel: +81 (03) 3265-7291
Fax: +81 (03) 3265-7298

**Emhart
Teknologies**
POP®

A BLACK&DECKER COMPANY