

Multiple grip all-steel breakstem rivet. Unique crimp design provides wide grip range and smooth bubble formation on tailside. Available in low profile, large flange, and countersunk head styles.

Benefits:

- **Wide Grip Range**
One rivet can be used in multiple material thicknesses, a very unique feature for an all-steel breakstem rivet.
- **Mechanically Locked Stem**
Stem is locked in shell, eliminating the risk of mandrel head vibrating loose while providing a weather resistant joint.
- **Complete Hole Fill**
The bulbing formation of the Stavex® will fill slightly oversized or irregular holes, providing increased strength and vibration resistance.

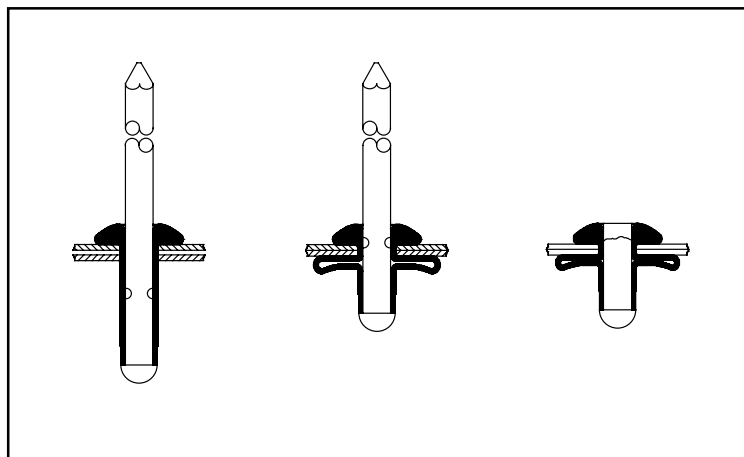

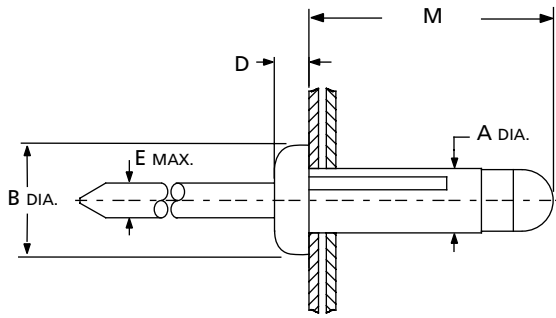

Lo-Profile Head

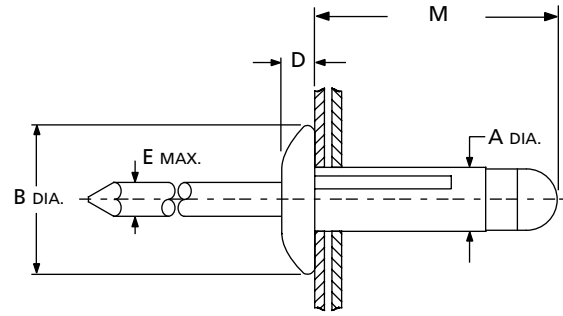

Large Flange Head

IDENTIFICATION CODE:

Prefix is rivet style and material

For example, OBS01 is steel Stavex with a low profile head

The second and third digits of suffix denote diameter in 32nds of an inch

Last two digits of suffix denote approximate rivet length to end of body in 32nds of an inch

OBS01-006-18

Series	Head Style	Material		Finish	
		Rivet	Mandrel	Rivet	Mandrel
OBF01	Lo Profile	Aluminum	Aluminum	Plain	Plain
OBF41	Large Flange	Aluminum	Aluminum	Plain	Plain
OBF11	Lo Profile	Aluminum	Aluminum	Black Anodized	Plain

Nom. Rivet Diam.	Hole Size	E Max.	A Max. Rivet Diam.	Lo-Profile Head		Large-Flange Head	
				B Nom. Head Diam.	D Max. Head Ht.	B Nom. Head Diam.	D Max. Head Ht.
5/32" (4,0mm)	.165-.177 (4,20-4,50)	.090 (2,27)	.165 (4,19)	.312 (7,90)	.060 (1,53)		
3/16" (4,8mm)	.197-.207 (5,00-5,25)	.112 (2,83)	.197 (5,00)	.387 (9,83)	.080 (2,04)	.610 (15,50)	.080 (2,04)

Rivet Diam.	Typical Rivet Shear and Tensile Strength lbf (N) BULBEX® Fasteners	
	OBF01/OBF41/OBF11 Aluminum	
	Shear	Tensile
5/32" (4,8mm)	135 (600)	225 (1000)
3/16" (6,3mm)	175 (780)	240 (1070)

Rivet Diam.	Grip Range	M Max.	Series OBF01 Aluminum Rivet Aluminum Mandrel	Series OBF41 Aluminum Rivet Aluminum Mandrel	Series OBF11 Aluminum Rivet Aluminum Mandrel
5/32" (4,0mm)	.040-.118 (1,00-3,00)	.630 (16,00)	OBF01-00516		OBF11-00516
	.040-.275 (1,00-7,50)	.840 (21,20)	OBF01-00523		OBF11-00523
3/16" (4,8mm)	.040-.157 (1,00-4,00)	.720 (18,30)	OBF01-00619	OBF41-00619	OBF11-00619
	.040-.354 (1,00-9,00)	.920 (23,30)	OBF01-00625	OBF41-00625	OBF11-00625
	.157-.472 (4,00-12,00)	1.07 (27,10)	OBF01-00630		OBF11-00630